

PETERSEN ALUMINUM CORPORATION TEST REPORT

SCOPE OF WORK

TAS 125 UPLIFT RESISTANCE TESTING OF 0.032" X 18" WIDE ALUMINUM SNAP-CLAD
STANDING SEAM ROOF SYSTEM OVER 1/2" PLYWOOD

REPORT NUMBER

M5239.04-450-18 R0

TEST DATE(S)

07/28/16 – 02/26/21

ISSUE DATE

07/29/21

PAGES

18

DOCUMENT CONTROL NUMBER

RT-R-AMER-Test-2958 (03/11/20)

© 2017 INTERTEK

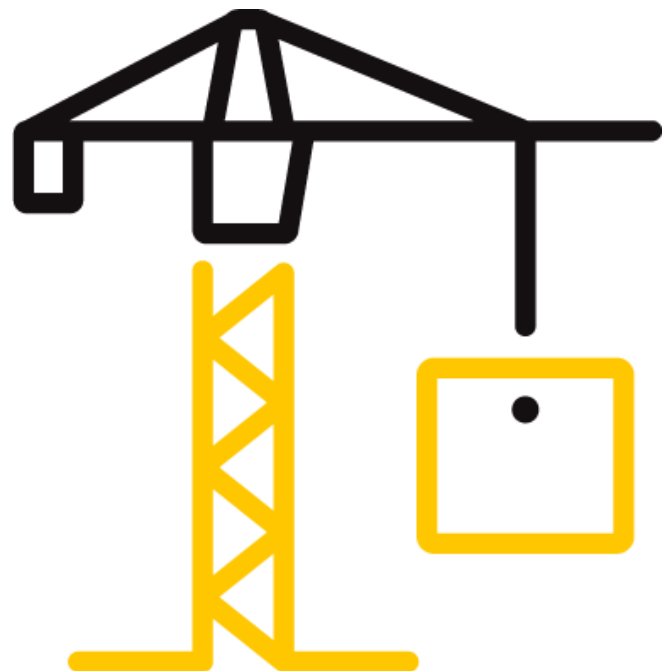

TEST REPORT FOR PETERSEN ALUMINUM CORPORATION

Report No.: M5239.04-450-18 R0

Date: 07/29/21

REPORT ISSUED TO

PETERSEN ALUMINUM CORPORATION

102 Northpoint Parkway Ext.

Acworth, Georgia 30102

SECTION 1

SCOPE

Architectural Testing, Inc. (an Intertek company), dba Intertek Building & Construction (B&C) was contracted by Petersen Aluminum Corporation to perform testing in accordance with TAS 125, *Standard Requirements for Metal Roofing Systems*, on their 0.032" x 18" Wide Aluminum Snap-Clad Roof Panels. Results obtained are tested values and were secured by using the designated test method(s). Testing was conducted at Intertek B&C test facility in West Palm Beach, FL.

This report does not constitute certification of this product nor an opinion or endorsement by this laboratory. Intertek B&C will service this report for the entire test record retention period. The test record retention period ends four years after the test date. Test records, such as detailed drawings, datasheets, representative samples of test specimens, or other pertinent project documentation, will be retained for the entire test record retention period.

Unless differently required, Intertek reports apply the "Simple Acceptance" rule, also called "Shared Risk approach," of ILAC-G8:09/2019, Guidelines on Decision Rules and Statements of Conformity.

For INTERTEK B&C:

COMPLETED BY:	Melissa Nuttall	REVIEWED BY:	Vinu J. Abraham, P.E.
TITLE:	Technician Team Leader – Product Testing	TITLE:	Vice President – Products
SIGNATURE:		SIGNATURE:	
DATE:	07/29/21	DATE:	07/29/21

MMN:sar

This report is for the exclusive use of Intertek's Client and is provided pursuant to the agreement between Intertek and its Client. Intertek's responsibility and liability are limited to the terms and conditions of the agreement. Intertek assumes no liability to any party, other than to the Client in accordance with the agreement, for any loss, expense or damage occasioned by the use of this report. Only the Client is authorized to permit copying or distribution of this report and then only in its entirety. Any use of the Intertek name or one of its marks for the sale or advertisement of the tested material, product or service must first be approved in writing by Intertek. The observations and test results in this report are relevant only to the sample(s) tested. This report by itself does not imply that the material, product, or service is or has ever been under an Intertek certification program.

TEST REPORT FOR PETERSEN ALUMINUM CORPORATION

Report No.: M5239.04-450-18 R0

Date: 07/29/21

SECTION 2

SUMMARY OF TEST RESULTS

Product Type: Metal Roof Panels

Series/Model: Snap-Clad

Specimen 1 – Ultimate Test Load Achieved: -127psf

Specimen 2 – Ultimate Test Load Achieved: -307psf

SECTION 3

TEST METHOD(S)

The specimens were evaluated in general accordance with the following:

TAS 125-03, *Standard Requirements for Metal Roofing Systems* (Only 2 field specimens tested)

SECTION 4

MATERIAL SOURCE/INSTALLATION

Test specimens were provided by the client. Representative samples of the test specimen(s) will be retained by Intertek B&C for a minimum of four years from the test completion date.

Installation of the tested product was performed by representatives of the client.

SECTION 5

EQUIPMENT

Cycling and Static Load Mechanism: Computer controlled centrifugal blowers with electronic pressure measuring device.

Deflection Measuring Device: Linear Transducers

SECTION 6

LIST OF OFFICIAL OBSERVERS

NAME	COMPANY
Veron Wickham	Intertek B&C
Melissa Nuttall	Intertek B&C

TEST REPORT FOR PETERSEN ALUMINUM CORPORATION

Report No.: M5239.04-450-18 R0

Date: 07/29/21

SECTION 7

TEST PROCEDURE

This test evaluates the comparative resistance of roof assemblies to positive and negative pressures by simulating the effects of wind gusts by use of oscillating exterior pressure and constant interior pressures. Two assemblies were tested per TAS 125 at each class rating. (Reference Chart No. 1 for test pressures and load durations.) The measurements were taken via linear transducers for specimen 1. For Specimen 2, the measurements were taken via a transit and steel scales mounted to the roof panels. The initial measurements were "zero" point, not actual deflection. Actual deflection is Phase 1, 2, 3 maximum, 4 or 5 reading less the initial (0.0 psf) reading. The final reading was taken after the completion of an entire class had been completed and became the initial reading for the following class test.

TEST PHASE	DURATION minutes	NEGATIVE PRESSURE		POSITIVE PRESSURE	
		POUNDS PER SQUARE FOOT psf (kPa)	INCHES OF WATER inches (mm)	POUNDS PER SQUARE FOOT psf (kPa)	INCHES OF WATER inches (mm)
Class 30 (maximum combined uplift pressure of -45 psf)					
1	5	16.2 (0.79)	3.1 (79)	0.0 (0.00)	0.0 (0)
2	5	16.2 (0.79)	3.1 (79)	13.8 (0.66)	2.7 (69)
3	60	8.1 - 27.7 (0.39 - 1.33)	1.5 - 5.3 (38 - 135)	13.8 (0.66)	2.7 (69)
4	5	24.2 (1.16)	4.7 (119)	0.0 (0.00)	0.0 (0)
5	5	24.2 (1.16)	4.7 (119)	20.8 (1.00)	4.0 (102)
Class 60 (maximum combined uplift pressure of -75 psf)					
1	5	32.3 (1.55)	6.2 (157)	0.0 (0.00)	0.0 (0)
2	5	32.3 (1.55)	6.2 (157)	27.7 (1.33)	5.3 (135)
3	60	16.2 - 55.4 (0.79 - 2.66)	3.1 - 10.7 (79 - 272)	27.7 (1.33)	5.3 (135)
4	5	40.4 (1.94)	7.8 (198)	0.0 (0.00)	0.0 (0)
5	5	40.4 (1.94)	7.8 (198)	34.6 (1.66)	6.7 (170)
Class 90 (maximum combined uplift pressure of 105 psf)					
1	5	48.5 (2.33)	9.3 (236)	0.0 (0.00)	0.0 (0)
2	5	48.5 (2.33)	9.3 (236)	41.5 (1.99)	8.0 (203)
3	60	24.2 - 48.5 (1.16 - 2.33)	4.7 - 9.3 (119 - 236)	41.5 (1.99)	8.0 (203)
4	5	56.5 (2.71)	10.9 (277)	0.0 (0.00)	0.0 (0)
5	5	56.5 (2.71)	10.9 (277)	48.5 (2.33)	9.3 (236)

Chart No. 1
TAS 125 Load Table Test Pressures

TEST REPORT FOR PETERSEN ALUMINUM CORPORATION

Report No.: M5239.04-450-18 R0

Date: 07/29/21

SECTION 8

TEST SPECIMEN DESCRIPTION

Product Type: Metal Roof Panels

Series/Model: Snap-Clad

Product Size(s):

All Specimens

OVERALL AREA:	WIDTH		HEIGHT	
	millimeters	inches	millimeters	inches
9.3 m ² (100.0 ft ²)				
Overall Size	3048	120	3048	120
Panel Coverage	457	18	3048	120

The following description applies to all specimens.

Test Deck Construction:

The 10' 0" wide by 10' 0" long by 1' 3" deep test frame was fabricated from C15 by 33.9 steel channels. The test frame utilized joists constructed from Southern Yellow Pine 2 x 12 lumber located on two sides of the test frame and spaced 24" on center. The joists were secured to the test frame using two 1/2" x 3" long bolts with washers and nuts through an 8" long, 2" by 4" by 1/8" steel angle with pre-drilled fastener locations. The steel angles were welded to the test frame 24" on center. Southern Yellow Pine 2 x 12 lumber was utilized as cross members located at mid-span. 1/2" (15/32" min) thick 4-ply plywood sheathing was utilized on the top of the test deck. The plywood was secured using 8d coated ring shank nails spaced 6" on center.

TEST REPORT FOR PETERSEN ALUMINUM CORPORATION

Report No.: M5239.04-450-18 R0

Date: 07/29/21

Specimens #1 Roof System:

COMPONENTS	DETAILS	ATTACHMENT METHOD
30# Asphalt saturated organic felt paper	A single layer was used with a 2" overlap between adjacent sheets.	0.120" x 1-1/4" galvanized annular ring shank roofing nails with 32 Ga tin caps spaced 6" on center at the perimeter and overlaps, with two intermediate rows spaced 12" on center.
Vapor and moisture barrier	A single layer of QUIK-Stick HT membrane was applied over the felt paper.	Self-adhered to felt paper.
Fire barrier	A single layer of VersaShield was used with a 2" overlap between adjacent sheets.	Laid loosely over the membrane
Clip	Each individual clip was constructed from 20 Ga galvanized steel and measured 1.982" wide x 1.875" high x 3.500" long.	Each clip was hooked over the male leg of the panel and attached using two #10 x 1-1/2" pancake head screws. The clips were located 6" from each end and 36" on center.
Roof Panel	The panels were constructed from 0.032" aluminum and had an 18" coverage width. Six full panels and two partial panels were tested.	The panel female leg was snap fit over the adjacent male panel leg and clips. The panel perimeters were secured using a single row of #10 x 1-1/2" pancake head screws spaced 2" on center.

TEST REPORT FOR PETERSEN ALUMINUM CORPORATION

Report No.: M5239.04-450-18 R0

Date: 07/29/21

Specimens #2 Roof System:

COMPONENTS	DETAILS	ATTACHMENT METHOD
30# Asphalt saturated organic felt paper	A single layer was used with a 2" overlap between adjacent sheets.	0.120" x 1-1/4" galvanized annular ring shank roofing nails with 32 Ga tin caps spaced 6" on center at the perimeter and overlaps, with two intermediate rows spaced 12" on center.
Vapor and moisture barrier	A single layer of QUIK-Stick HT membrane was applied over the felt paper.	Self-adhered to felt paper.
Fire barrier	A single layer of VersaShield was used with a 2" overlap between adjacent sheets.	Laid loosely over the membrane
Clip	Each individual clip was constructed from 20 Ga galvanized steel and measured 1.982" wide x 1.875" high x 3.500" long.	Each clip was hooked over the male leg of the panel and attached using two #10 x 1-1/2" pancake head screws. The clips were located 6" from each end and 6" on center.
Roof Panel	The panels were constructed from 0.032" aluminum and had an 18" coverage width. Six full panels and two partial panels were tested.	The panel female leg was snap fit over the adjacent male panel leg and clips. The panel perimeters were secured using a single row of #10 x 1-1/2" pancake head screws spaced 2" on center.

TEST REPORT FOR PETERSEN ALUMINUM CORPORATION

Report No.: M5239.04-450-18 R0

Date: 07/29/21

SECTION 9

TEST RESULTS

Test Specimen #1

TEST TITLE	OBSERVATIONS	DEFLECTION MEASUREMENTS	RESULTS
Class 30, Phases 1-5	No visible damage to system	Reference Table No. 1	PASSED
Class 60, Phases 1-5	No visible damage to system	Reference Table No. 1	PASSED
Class 90, Phases 1-5	No visible damage to system	Reference Table No. 1	PASSED
Supplemental Loads -112 psf to -127 psf	No visible damage to system	Reference Table No. 2	PASSED
Supplemental Loads -142 psf	Seam disengaged	Reference Table No. 2	FAILED

Test Specimen #2

TEST TITLE	OBSERVATIONS	DEFLECTION MEASUREMENTS	RESULTS
Class 30, Phases 1-5	No visible damage to system	Reference Table No. 3	PASSED
Class 60, Phases 1-5	No visible damage to system	Reference Table No. 3	PASSED
Class 90, Phases 1-5	No visible damage to system	Reference Table No. 3	PASSED
Supplemental Loads -112 psf to -307 psf	No visible damage to system	Reference Table No. 4	PASSED
Supplemental Loads -322 psf	Seam disengaged	Reference Table No. 4	FAILED

Notes:

Reference Chart No. 1 for test pressures and load durations.

Reference Sketch No. 1 for location of deflection measurement devices.

A loose fitting, pleated 4-mil plastic film was utilized to assist in obtaining uniform pressure on the roof system. The plastic film was located between the moisture barrier and the roof panels to facilitate testing. In our opinion, this did not influence test results.

Supplemental loads per UL 1897 started at -112 psf total load.



Total Quality. Assured.

2658 Electronics Way
West Palm Beach, Florida 33407

Telephone: 561-881-0020
Facsimile: 717-764-4129
www.intertek.com/building

TEST REPORT FOR PETERSEN ALUMINUM CORPORATION

Report No.: M5239.04-450-18 R0

Date: 07/29/21

SECTION 10

CONCLUSION

The product tested per TAS 125 achieved:

Specimen 1 – Ultimate Test Load: -127psf

Specimen 2 – Ultimate Test Load: -307psf

TEST REPORT FOR PETERSEN ALUMINUM CORPORATION

Report No.: M5239.04-450-18 R0

Date: 07/29/21

SECTION 11 SKETCH(ES)

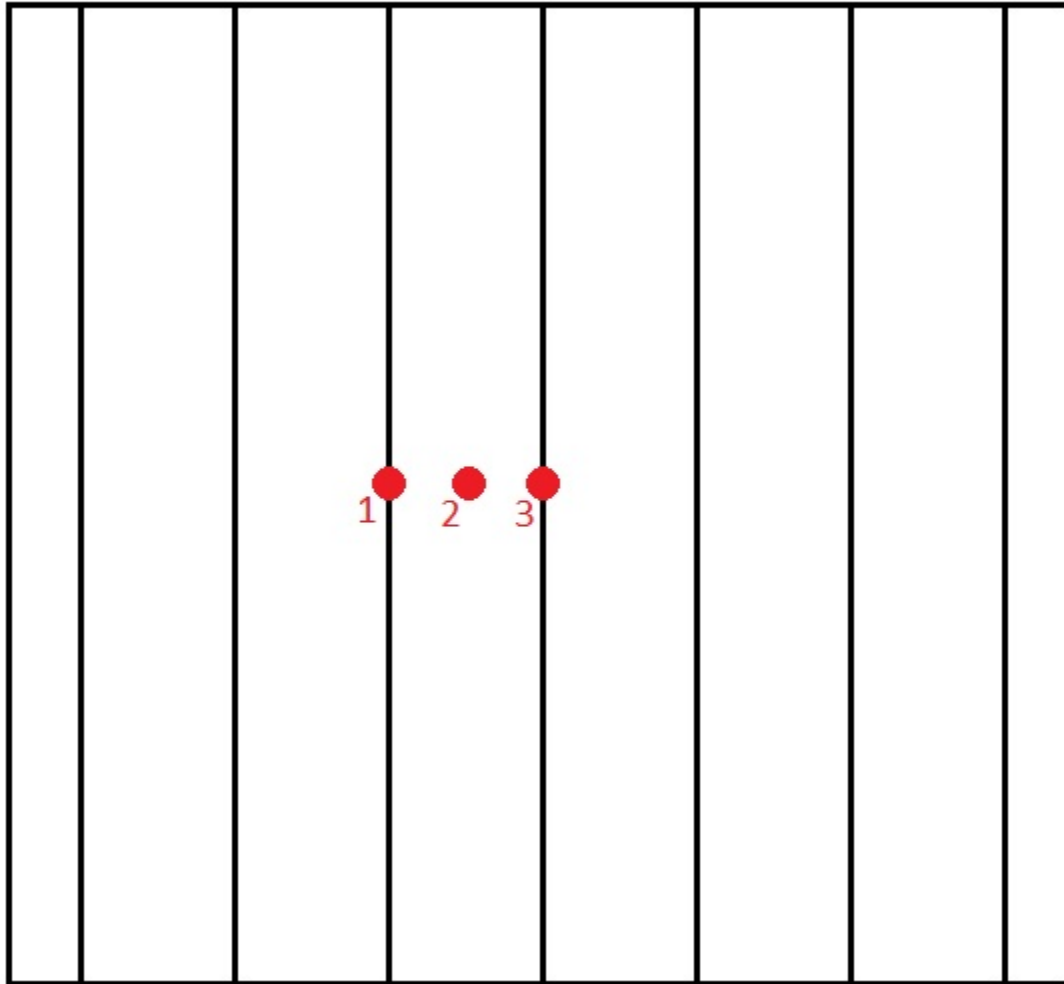

Sketch No. 1
Deflection Measurement Device Locations

TEST REPORT FOR PETERSEN ALUMINUM CORPORATION

Report No.: M5239.04-450-18 R0

Date: 07/29/21

SECTION 12

DEFLECTION TABLES

CLASS	PHASE	DEFLECTION MEASUREMENTS (inches)		
		INDICATOR		
		#1	#2	#3
30 (-45 psf Max.)	1	0.08	0.73	0.17
	2	0.11	0.78	0.20
	3 Minimum	0.13	0.81	0.21
	3 Maximum	0.16	0.93	0.26
	4	0.16	0.97	0.27
	5	0.21	1.16	0.40
	Final (0.0 psf)	0.09	0.20	0.11
60 (-75 psf Max.)	1	0.17	1.16	0.39
	2	0.24	1.41	0.54
	3 Minimum	0.32	1.45	0.56
	3 Maximum	0.32	1.65	0.70
	4	0.35	1.49	0.59
	5	0.42	1.68	0.75
	Final (0.0 psf)	0.17	0.29	0.17
90 (-105 psf Max.)	1	0.38	1.60	0.66
	2	0.52	1.86	0.90
	3 Minimum	0.48	1.62	0.77
	3 Maximum	0.51	1.71	0.87
	4	0.53	1.69	0.77
	5	0.79	2.05	1.05
	Final (0.0 psf)	0.31	0.41	0.23

Table No. 1
Deflection Measurements – Test Specimen #1

TEST REPORT FOR PETERSEN ALUMINUM CORPORATION

Report No.: M5239.04-450-18 R0

Date: 07/29/21

VACUUM (psf)	UPLIFT (psf)	LOAD (psf)	SUPPLEMENTAL DEFLECTION MEASUREMENTS (inches)		
			INDICATOR		
			#1	#2	#3
-63.5	-48.5	-112.0	0.83	2.00	1.08
-78.5	-48.5	-127.0	0.96	2.36	1.27
-93.5	-48.5	-142.0	Failed		

Table No. 2
Supplemental Deflection Measurements – Test Specimen #1

TEST REPORT FOR PETERSEN ALUMINUM CORPORATION

Report No.: M5239.04-450-18 R0

Date: 07/29/21

CLASS	PHASE	DEFLECTION MEASUREMENTS (inches)		
		INDICATOR		
		#1	#2	#3
30	Initial (0.0 psf)	4.3	4.6	4.3
	1	4.4	4.8	4.4
	2	4.5	5.1	4.5
	3 Minimum	4.5	5.1	4.5
	3 Maximum	4.5	5.2	4.5
	4	4.5	5.0	4.5
	5	4.5	5.3	4.6
	Final (0.0 psf)	4.3	4.6	4.3
60	1	4.5	5.2	4.5
	2	4.6	5.3	4.6
	3 Minimum	4.5	5.3	4.6
	3 Maximum	4.6	5.5	4.7
	4	4.6	5.3	4.6
	5	4.7	5.5	4.7
	Final (0.0 psf)	4.5	5.2	4.5
90	1	4.6	5.4	4.7
	2	4.7	5.6	4.8
	3 Minimum	4.7	5.5	4.6
	3 Maximum	4.7	5.6	4.7
	4	4.7	5.4	4.7
	5	4.8	5.8	4.8
	Final (0.0 psf)	4.6	5.4	4.7

Table No. 3
Deflection Measurements – Test Specimen #2

TEST REPORT FOR PETERSEN ALUMINUM CORPORATION

Report No.: M5239.04-450-18 R0

Date: 07/29/21

VACUUM (psf)	UPLIFT (psf)	LOAD (psf)	SUPPLEMENTAL DEFLECTION MEASUREMENTS (inches)		
			INDICATOR		
			#1	#2	#3
-63.5	-48.5	-112.0	4.9	5.7	4.8
-78.5	-48.5	-127.0	4.9	5.8	4.9
-93.5	-48.5	-142.0	4.9	6.0	5.0
-108.5	-48.5	-157.0	5.0	6.1	5.0
-123.5	-48.5	-172.0	5.0	6.3	5.1
-138.5	-48.5	-187.0	5.1	6.4	5.2
-153.5	-48.5	-202.0	5.1	6.5	5.2
-168.5	-48.5	-217.0	5.2	6.7	5.3
-183.5	-48.5	-232.0	5.2	6.8	5.4
-198.5	-48.5	-247.0	5.3	6.9	5.4
-213.5	-48.5	-262.0	5.3	7.0	5.5
-228.5	-48.5	-277.0	5.4	7.1	5.5
-243.5	-48.5	-292.0	5.4	7.3	5.5
-258.5	-48.5	-307.0	5.5	7.4	5.6
-273.5	-48.5	-322.0	Failed		

Table No. 4
Supplemental Deflection Measurements – Test Specimen #2

TEST REPORT FOR PETERSEN ALUMINUM CORPORATION

Report No.: M5239.04-450-18 R0

Date: 07/29/21

SECTION 13

LOAD TABLE

Load Table: 0.032" x 18" Wide Aluminum Snap-Clad Panel Over 1/2" Plywood

Clip Spacing, L	Clip Spacing, L	Test Result	Allowable Design Pressure with Safety Factor of 1.65	Allowable Design Pressure with Safety Factor of 2.00
0'-6"	6"	-307.0 psf	-186.1 psf	-153.5 psf
1'-0"	12"		-164.2 psf	-135.5 psf
1'-6"	18"		-142.5 psf	-117.5 psf
2'-0"	24"		-120.6 psf	-99.5 psf
2'-6"	30"		-98.8 psf	-81.5 psf
3'-0"	36"	-127.0 psf	-77.0 psf	-63.5 psf

General Notes:

Intermediate values based on linear interpolation from tested values.

Actual testing was conducted at 0'-6" and 3'-0" clip spacing.

Vinu Abraham
Vice President - Products
July 29, 2021

TEST REPORT FOR PETERSEN ALUMINUM CORPORATION

Report No.: M5239.04-450-18 R0

Date: 07/29/21

SECTION 14 DRAWINGS

The test specimen drawings have been reviewed by Intertek B&C and are representative of the test specimen(s) reported herein. Test specimen construction was verified by Intertek B&C per the drawings included in this report. Any deviations are documented herein or on the drawings.

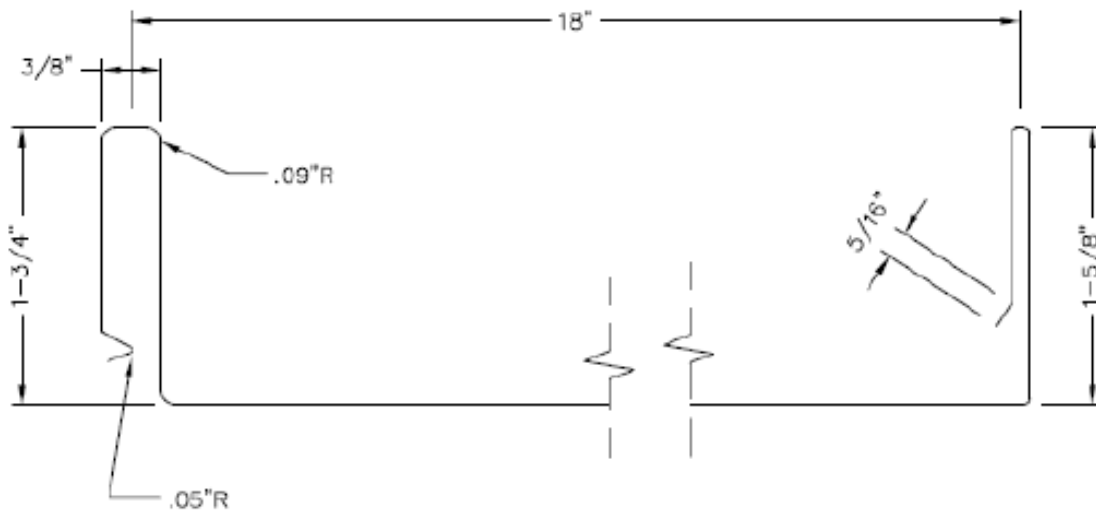

**Drawing No. 1
Panel Profile**



**Drawing No. 2
Seam Detail**

TEST REPORT FOR PETERSEN ALUMINUM CORPORATION

Report No.: M5239.04-450-18 R0

Date: 07/29/21

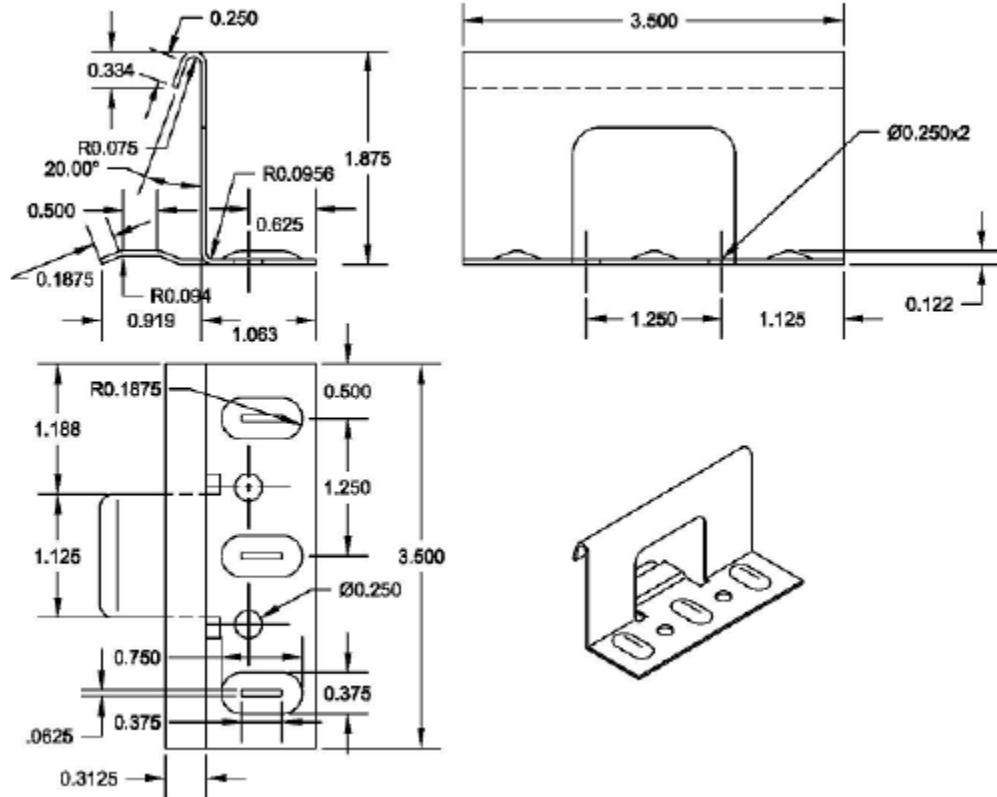

Drawing No. 3
Clip Dimensions



Total Quality. Assured.

2658 Electronics Way
West Palm Beach, Florida 33407

Telephone: 561-881-0020
Facsimile: 717-764-4129
www.intertek.com/building

TEST REPORT FOR PETERSEN ALUMINUM CORPORATION

Report No.: M5239.04-450-18 R0

Date: 07/29/21

SECTION 15

REVISION LOG

REVISION #	DATE	PAGES	REVISION
0	07/29/21	N/A	Original Report Issue